

RACAL INSTRUMENTS 1260-136 MULTIPLEXER PLUG-IN

PUBLICATION NO. 980824-136

EADS North America Defense Test and Services, Inc.
4 Goodyear, Irvine, CA 92618
Tel: (800) 722-2528, (949) 859-8999; Fax: (949) 859-7139

info@eads-nadefense.com
sales@eads-nadefense.com
helpdesk@eads-nadefense.com
<http://www.eads-nadefense.com>



PUBLICATION DATE: November 10, 2004

Copyright 1999 by EADS North America Defense Test and Services, Inc. Printed in the United States of America. All rights reserved. This book or parts thereof may not be reproduced in any form without written permission of the publisher.

**THANK YOU FOR PURCHASING THIS
EADS NORTH AMERICA DEFENSE TEST AND SERVICES PRODUCT**

For this product, or any other EADS North America Defense Test and Services, Inc. product that incorporates software drivers, you may access our web site to verify and/or download the latest driver versions. The web address for driver downloads is:

<http://www.eads-nadefense.com/downloads>

If you have any questions about software driver downloads or our privacy policy, please contact us at

info@eads-nadefense.com

WARRANTY STATEMENT

All EADS North America Defense Test and Services, Inc. products are designed and manufactured to exacting standards and in full conformance to EADS ISO 9001:2000 processes.

This warranty does not apply to defects resulting from any modification(s) of any product or part without EADS North America Defense Test and Services, Inc. express written consent, or misuse of any product or part. The warranty also does not apply to fuses, software, non-rechargeable batteries, damage from battery leakage, or problems arising from normal wear, such as mechanical relay life, or failure to follow instructions.

This warranty is in lieu of all other warranties, expressed or implied, including any implied warranty of merchantability or fitness for a particular use. The remedies provided herein are buyer's sole and exclusive remedies.

For the specific terms of your standard warranty, or optional extended warranty or service agreement, contact your EADS North America Defense Test and Services, Inc. customer service advisor. Please have the following information available to facilitate service.

1. Product serial number
2. Product model number
3. Your company and contact information

You may contact your customer service advisor by:

| | | |
|------------|--|-------|
| E-Mail: | Helpdesk@eads-nadefense.com | |
| Telephone: | +1 800 722 3262 | (USA) |
| Fax: | +1 949 859 7309 | (USA) |

RETURN of PRODUCT

Authorization is required from EADS North America Defense Test and Services, Inc. before you send us your product for service or calibration. Call or contact the Customer Support Department at 1-800-722-3262 or 1-949-859-8999 or via fax at 1-949-859-7139. We can be reached at: helpdesk@eads-nadefense.com.

PROPRIETARY NOTICE

This document and the technical data herein disclosed, are proprietary to EADS North America Defense Test and Services, Inc., and shall not, without express written permission of EADS North America Defense Test and Services, Inc., be used, in whole or in part to solicit quotations from a competitive source or used for manufacture by anyone other than EADS North America Defense Test and Services, Inc. The information herein has been developed at private expense, and may only be used for operation and maintenance reference purposes or for purposes of engineering evaluation and incorporation into technical specifications and other documents which specify procurement of products from EADS North America Defense Test and Services, Inc.

DISCLAIMER

Buyer acknowledges and agrees that it is responsible for the operation of the goods purchased and should ensure that they are used properly and in accordance with this handbook and any other instructions provided by Seller. EADS North America Defense Test and Services, Inc. products are not specifically designed, manufactured or intended to be used as parts, assemblies or components in planning, construction, maintenance or operation of a nuclear facility, or in life support or safety critical applications in which the failure of the EADS North America Defense Test and Services, Inc. product could create a situation where personal injury or death could occur. Should Buyer purchase EADS North America Defense Test and Services, Inc. product for such unintended application, Buyer shall indemnify and hold EADS North America Defense Test and Services, Inc., its officers, employees, subsidiaries, affiliates and distributors harmless against all claims arising out of a claim for personal injury or death associated with such unintended use.

FOR YOUR SAFETY

Before undertaking any troubleshooting, maintenance or exploratory procedure, read carefully the **WARNINGS** and **CAUTION** notices.



CAUTION
RISK OF ELECTRICAL SHOCK
DO NOT OPEN



This equipment contains voltage hazardous to human life and safety, and is capable of inflicting personal injury.



If this instrument is to be powered from the AC line (mains) through an autotransformer, ensure the common connector is connected to the neutral (earth pole) of the power supply.



Before operating the unit, ensure the conductor (green wire) is connected to the ground (earth) conductor of the power outlet. Do not use a two-conductor extension cord or a three-prong/two-prong adapter. This will defeat the protective feature of the third conductor in the power cord.



Maintenance and calibration procedures sometimes call for operation of the unit with power applied and protective covers removed. Read the procedures and heed warnings to avoid “live” circuit points.

Before operating this instrument:

1. Ensure the proper fuse is in place for the power source to operate.
2. Ensure all other devices connected to or in proximity to this instrument are properly grounded or connected to the protective third-wire earth ground.

If the instrument:

- fails to operate satisfactorily
- shows visible damage
- has been stored under unfavorable conditions
- has sustained stress

Do not operate until performance is checked by qualified person.

Racal Instruments

EC Declaration of Conformity

We

Racal Instruments Inc.
4 Goodyear Street
Irvine, CA 92718

declare under sole responsibility that the

1260-136B High Voltage Mux P/N 407698-002
1260-136C High Voltage Mux P/N 407698-003
1260-136D High Voltage Mux P/N 407698-004

conform to the following Product Specifications:

Safety: EN 61010-1

EMC: EN50081-1
CISPR 11:1990/EN 55011 (1991): Group 1 Class A
IEC 801-2:1991/EN 50082-1 (1992): 4 kV CD, 8 kV AD
IEC 801-3:1984/EN 50082-1 (1992): 3 V/m, 27-500 MHz
IEC 801-4:1988/EN 50082-1 (1992): 1 kV

Supplementary Information:

The above specifications are met when the product is installed in a Racal Instruments Adapt-a-Switch Carrier with faceplates installed over all unused slots, as applicable. The carrier is installed in a certified mainframe.

The product herewith complies with the requirements of the Low Voltage Directive 73/23/EEC and the EMC Directive 89/336/EEC.

Irvine, CA, July 26, 1999

Quality Manager

This page was left intentionally blank.

Table of Contents

| | |
|-------------------------------------|-----|
| Chapter 1 | 1-1 |
| SPECIFICATIONS | 1-1 |
| Introduction – 1260-136B | 1-1 |
| Specifications – 1260-136B..... | 1-2 |
| Power Dissipation – 1260-136B | 1-3 |
| Introduction – 1260-136C | 1-4 |
| Specifications – 1260-136C | 1-4 |
| Power Dissipation – 1260-136C..... | 1-5 |
| Introduction – 1260-136D..... | 1-6 |
| Specifications – 1260-136D | 1-7 |
| Power Dissipation – 1260-136D..... | 1-8 |
| About MTBF | 1-9 |
| Ordering Information | 1-9 |
| Chapter 2 | 2-1 |
| INSTALLATION INSTRUCTIONS..... | 2-1 |
| Unpacking and Inspection | 2-1 |
| Reshipment Instructions..... | 2-1 |
| Installation | 2-1 |
| Module Configuration | 2-2 |
| Front Panel Connectors..... | 2-2 |
| Mating Connectors..... | 2-4 |

| | |
|--|------|
| Chapter 3 | 3-1 |
| MODULE OPERATION | 3-1 |
| Setting the Module Address | 3-1 |
| Operating Modes | 3-2 |
| Operating In Message-Based Mode..... | 3-4 |
| Port Descriptors For The 1260-136 | 3-4 |
| Reply To The MOD:LIST? Command..... | 3-5 |
| Operating The 1260-136 in Register-Based Mode..... | 3-6 |
| 1260-136 Example Code..... | 3-11 |
| Chapter 4 | 4-1 |
| OPTIONAL ASSEMBLIES | 4-1 |
| Chapter 5 | 5-1 |
| Product Support | 5-1 |
| Warranty..... | 5-1 |

List of Figures

Figure 1-1, 1260-1361-1

Figure 1-2, 1260-136D in the vertical position1-6

Figure 2-1, Front-Panel Connector Pin Numbering2-2

Figure 2-2, Relay Diagram.....2-3

Figure 2-3, Block Diagram2-4

Figure 3-1, Message-Based Mode of Operation3-3

Figure 3-2, Register-Based Mode of Operation3-3

List of Tables

| | |
|--|------|
| Table 2-1, 1260-136 Front-Panel Connections..... | 2-3 |
| Table 3-1, Register Offset Addresses of the 1260-136 Module..... | 3-7 |
| Table 3-2, ID Register Functionality of the 1260-136 | 3-7 |
| Table 3-3, Port A Register Functionality of the 1260-136 Module | 3-8 |
| Table 3-4, Port B Register Functionality of the 1260-136 Module | 3-8 |
| Table 3-5, Port C Register Functionality of the 1260-136 Module | 3-8 |
| Table 3-6, Port D Register Functionality of the 1260-136 Module | 3-9 |
| Table 3-7, Port E Register Functionality of the 1260-136 Module | 3-9 |
| Table 3-8, Port F Register Functionality of the 1260-136 Module | 3-9 |
| Table 3-9, EPROM Descriptor Functionality of the 1260-136 Module | 3-10 |

Chapter 1

SPECIFICATIONS

Introduction – 1260-136B

The 1260-136B is a plug-in switch module developed for the 1260-100 Adapt-a-Switch Carrier. This switch is a software-configurable 1X42 or 2X21 switch which provides up to 500VDC channel isolation at 0.5A/10W.

The 1260-136B includes the following features:

- Standard Adapt-a-Switch™ plug-in design, providing for ease of replacement
- Data-Driven embedded descriptor, allowing immediate use with any Option-01T switch controller, regardless of firmware revision level.



Figure 1-1, 1260-136

Specifications – 1260-136B

| | |
|--------------------------------------|---|
| Chan. Input Voltage | 500VDC maximum [†] 500VAC _{pk-pk} |
| Chan. Output Current | 0.5 A maximum |
| Chan. Output Power | 10 W maximum |
| Path Resistance | 0.850 Ω maximum |
| Contact Bounce Time | 0.25 ms typical |
| Switch Contact Lifetime | 100 Million Cycles (low-level) 1 Million Cycles (maximum rating) |
| Available I/O Channels | 21 (dual wire mode) 42 (single wire mode) |
| Breakdown Voltage | 1500 VDC |
| Insulation Resistance | 10 ⁹ ohms |
| Shock | 30g, 11 ms, ½ sine wave |
| Vibration | 0.013 in. P-P, 5-55 Hz |
| Bench Handling | 4 in., 45° |
| Cooling | See 1260-100 cooling data |
| Temperature | |
| Operating | 0°C to +55°C |
| Non-operating | -40°C to +75°C |
| Relative Humidity | 85% + 5% non-condensing at < 30°C |
| Altitude | |
| Operating | 10,000 feet |
| Non-operating | 15,000 feet |
| Power Requirements | |
| +5 VDC | 1.2 A maximum with all channels closed |
| Weight | 9 oz. |
| Mean Time Between Failures (MTBF) | TBD |
| Channel to Chassis Capacitance | <150pF |
| Mean Time to Repair | < 5 minutes (MTTR) |

[†]Refer to warning about high-voltages in [Chapter 2: Installation Instructions](#)

Power Dissipation – 1260-136B

The cooling of the Adapt-a-Switch carrier is dependent upon the chassis into which it is installed. The carrier can nominally dissipate approximately 100W. Even with all channels driven to maximum outputs, up to six 1260-136 plug-ins may be used together in a 1260-100 without exceeding the maximum allowable power dissipation of the carrier.

If the 1260-136B will be used in conjunction with other cards, the dissipation should be computed and summed with the total worst-case dissipation of the remaining modules.

For example, a 1260-136B module would dissipate the following energy:

Quiescent power dissipation = 0.75W maximum

Channel dissipation =
[(# channels energized) * (relay coil dissipation)] +
[(channel current)² * (path resistance) * 2]

Total Power Dissipation = Quiescent + Channel

Assuming the card is configured in the 2X21 mode of operation (worse case situation) operating with the maximum path current allowed in the A and B commons of 0.5A, a path resistance of 0.850Ω, and all relays engaged:

Total power dissipation =
[(42) * (0.085)] + [(0.5)² * (0.850) * 2] + {0.75} = 4.75W

This is acceptable power dissipation for an individual plug-in module. If five additional modules are likewise loaded, then the overall carrier dissipation is approximately 27W, which is well within the cooling available in most commercial VXIbus chassis. Since the 1260-136 is a multiplexer card, having all relays engaged at once is unlikely and the power dissipation falls down further. For practical purposes, as the calculations illustrate, the 1260-136 contributes a negligible amount of thermal load on a chassis.

Introduction – 1260-136C

The 1260-136C is a plug-in switch module developed for the 1260-100 Adapt-a-Switch Carrier. This switch is a software-configurable 1X42 or 2X21 switch which provides up to 1000VDC channel isolation at 1.0A/25W.

The 1260-136C includes the following features:

1. Standard Adapt-a-Switch™ plug-in design, providing for ease of replacement
2. Data-Driven embedded descriptor, allowing immediate use with any Option-01T switch controller, regardless of firmware revision level.

Specifications – 1260-136C

| | |
|-------------------------|---|
| Chan. Input Voltage | 1000VDC maximum† 1000VAC _{pk-pk} |
| Chan. Output Current | 1.0A maximum |
| Chan. Output Power | 25 W maximum |
| Path Resistance | 0.850Ω maximum |
| Contact Bounce Time | 0.25 ms typical |
| Switch Contact Lifetime | 100 Million Cycles (low-level) 1 Million Cycles (maximum rating) |
| Available I/O Channels | 21 (dual wire mode) 42 (single wire mode) |
| Breakdown Voltage | 1500 VDC |
| Insulation Resistance | 10 ⁹ ohms |
| Shock | 30g, 11 ms, ½ sine wave |
| Vibration | 0.013 in. P-P, 5-55 Hz |
| Bench Handling | 4 in., 45° |
| Cooling | See 1260-100 cooling data |
| Temperature | |
| Operating | 0°C to +55°C |
| Non-operating | -40°C to +75°C |
| Relative Humidity | 85% + 5% non-condensing at < 30°C |

| | |
|-----------------------------------|--|
| Altitude | |
| Operating | 10,000 feet |
| Non-operating | 15,000 feet |
| Power Requirements | |
| +5 VDC | 1.4 A maximum with all channels closed |
| Weight | 9 oz. |
| Mean Time Between Failures (MTBF) | TBD |
| Channel to Chassis Capacitance | <150pF |
| Mean Time to Repair | < 5 minutes (MTTR) |

†Refer to warning about high-voltages in Chapter 2: Installation Instructions

Power Dissipation – 1260-136C

The cooling of the Adapt-a-Switch carrier is dependent upon the chassis into which it is installed. The carrier can nominally dissipate approximately 100W. Even with all channels driven to maximum outputs, up to six 1260-136 plug-ins may be used together in a 1260-100 without exceeding the maximum allowable power dissipation of the carrier.

If the 1260-136C will be used in conjunction with other cards, the dissipation should be computed and summed with the total worst-case dissipation of the remaining modules.

For example, a 1260-136C module would dissipate the following energy:

Quiescent power dissipation = 0.75W maximum

Channel dissipation =
 $[(\# \text{ channels energized}) * (\text{relay coil dissipation})] +$
 $[(\text{channel current})^2 * (\text{path resistance}) * 2]$

Total Power Dissipation = Quiescent + Channel

Assuming the card is configured in the 2X21 mode of operation (worse case situation) operating with the maximum path current allowed in the A and B commons of 1A, a path resistance of 0.850Ω, and all relays engaged:

Total power dissipation =
 $[(42) * (0.125)] + [(1)^2 * (0.850) * 2] + \{0.75\} = 7.7W$

This is acceptable power dissipation for an individual plug-in module. If five additional modules are likewise loaded, then the overall carrier dissipation is approximately 40W, which is well within the cooling available in most commercial VXIbus chassis. Since the 1260-136 is a multiplexer card, having all relays engaged at once is unlikely and the power dissipation falls down further. For practical purposes, as the calculations illustrate, the 1260-136 contributes a negligible amount of thermal load on a chassis.

Introduction – 1260-136D

The 1260-136D is a plug-in switch module developed for the 1260-100 Adapt-a-Switch Carrier. This switch is a software-configurable 1X42 or 2X21 switch which provides up to 500VDC channel isolation at 1A/50W using mercury-wetted contacts for maximum reliability.

CAUTION

The 1260-136D is a position sensitive card and must be used with the card in the vertical position for correct operation (see the following diagram).

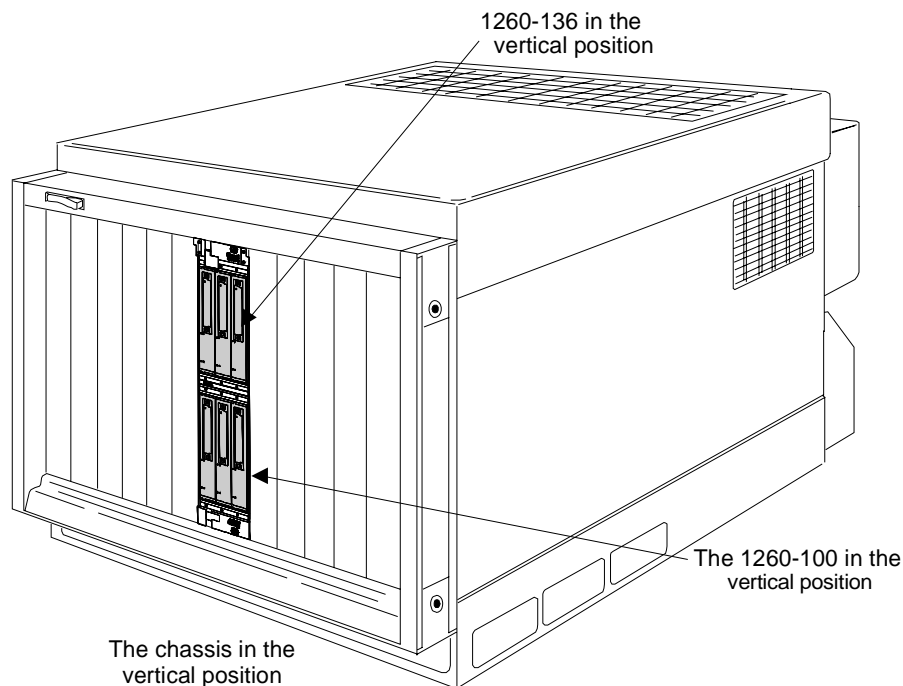

Figure 1-2, 1260-136D in the vertical position

The 1260-136D includes the following features:

- Standard Adapt-a-Switch™ plug-in design, providing for ease of replacement
- Data-Driven embedded descriptor, allowing immediate use with any Option-01T switch controller, regardless of firmware revision level.

Specifications – 1260-136D

| | |
|-------------------------|--|
| Chan. Input Voltage | 500VDC maximum† 500VAC _{pk-pk} |
| Chan. Output Current | 1 A maximum |
| Chan. Output Power | 50 W maximum |
| Path Resistance | 0.850 Ω maximum |
| Contact Bounce Time | none |
| Switch Contact Lifetime | 1 Billion Cycles (low-level) 50 Million Cycles (maximum rating) |
| Available I/O Channels | 21 (dual wire mode) 42 (single wire mode) |
| Breakdown Voltage | 1500 VDC |
| Insulation Resistance | 10 ⁹ ohms |
| Shock | 30g, 11 ms, ½ sine wave |
| Vibration | 0.013 in. P-P, 5-55 Hz |
| Bench Handling | 4 in., 45° |
| Cooling | See 1260-100 cooling data |
| Temperature | |
| Operating | 0°C to +55°C |
| Non-operating | -40°C to +75°C |
| Relative Humidity | 85% + 5% non-condensing at < 30°C |
| Altitude | |
| Operating | 10,000 feet |
| Non-operating | 15,000 feet |

| | |
|-----------------------------------|--|
| Power Requirements +5 VDC | 1.4 A maximum with all channels closed |
| Weight | 9 oz. |
| Mean Time Between Failures (MTBF) | TBD |
| Channel to Chassis Capacitance | <150pF |
| Mean Time to Repair | < 5 minutes (MTTR) |

†Refer to warning about high-voltages in [Chapter 2: Installation Instructions](#)

Power Dissipation – 1260-136D

The cooling of the Adapt-a-Switch carrier is dependent upon the chassis into which it is installed. The carrier can nominally dissipate approximately 100W. Even with all channels driven to maximum outputs, up to six 1260-136 plug-ins may be used together in a 1260-100 without exceeding the maximum allowable power dissipation of the carrier.

If the 1260-136D will be used in conjunction with other cards, the dissipation should be computed and summed with the total worst-case dissipation of the remaining modules.

For example, a 1260-136D module would dissipate the following energy:

Quiescent power dissipation = 0.75W maximum

Channel dissipation =

$$[(\# \text{ channels energized}) * (\text{relay coil dissipation})] +$$

$$[(\text{channel current})^2 * (\text{path resistance}) * 2]$$

Total Power Dissipation = Quiescent + Channel

Assuming the card is configured in the 2X21 mode of operation (worse case situation) operating with the maximum path current allowed in the A and B commons of 1A, a path resistance of 0.850Ω, and all relays engaged:

Total power dissipation =

$$[(42) * (0.125)] + [(1)^2 * (0.850) * 2] + \{0.75\} = 7.7W$$

This is acceptable power dissipation for an individual plug-in

module. If five additional modules are likewise loaded, then the overall carrier dissipation is approximately 39 W, which is well within the cooling available in most commercial VXIbus chassis. Since the 1260-136 is a multiplexer card, having all relays engaged at once is unlikely and the power dissipation falls down further. For practical purposes, as the calculations illustrate, the 1260-136 contributes a negligible amount of thermal load on a chassis.

About MTBF

The 1260-136 MTBF is TBD.

Ordering Information

Listed below are part numbers for both the 1260-136 switch module and available mating connector accessories. Each 1260-136 uses a single mating connector.

| ITEM | DESCRIPTION | PART # |
|------------------------------|--|---------------|
| 1260-136B 500V Switch Module | Switch Module, 1X42 / 2X21 500 VDC Consists of: P/N 405153-002 PCB Assy P/N 980824-136 Manual | 407698-002 |
| 1260-136C 1KV Switch Module | Switch Module, 1X42 / 2X21 1KV Consists of: P/N 405153-003 PCB Assy P/N 980824-136 Manual | 407698-003 |
| 1260-136D HG Switch Module | Switch Module, 1X42 / 2X21 500V Mercury-Wetted Consists of: P/N 405153-004 PCB Assy P/N 980824-136 Manual | 407698-004 |
| 160 Pin Connector Kit | 160 Pin Connector Kit | 407664-001 |
| Additional Manual | | 980824-136 |

This page was left intentionally blank.

INSTALLATION INSTRUCTIONS

Unpacking and Inspection



1. Remove the 1260-136 module and inspect it for damage. If any damage is apparent, inform the carrier immediately. Retain shipping carton and packing material for the carrier's inspection.
2. Verify that the pieces in the package you received contain the correct 1260-136 module option and the 1260-136 Users Manual. Notify EADS North America Defense Test and Services, Inc. if the module appears damaged in any way. Do not attempt to install a damaged module into a VXI chassis.
3. The 1260-136 module is shipped in an anti-static bag to prevent electrostatic damage to the module. Do not remove the module from the anti-static bag unless it is in a static-controlled area.

Reshipment Instructions

1. Use the original packing when returning the switching module to EADS North America Defense Test and Services, Inc. for calibration or servicing. The original shipping carton and the instrument's plastic foam will provide the necessary support for safe reshipment.
2. If the original packing material is unavailable, wrap the switching module in an ESD Shielding bag and use plastic spray foam to surround and protect the instrument.
3. Reship in either the original or a new shipping carton.

Installation

Installation of the 1260-136 Switching Module into a 1260-100 Carrier assembly is described in the Installation section of the 1260-100 Adapt-a-Switch Carrier Manual.

Module Configuration

The 1260-136 is a software-selectable 1X42 or 2X21 multiplexer I/O plug-in for the Adapt-a-Switch Series. It is available in several variations having different switching voltages, currents, and contact materials (refer to Chapter 1 for more information) to suit a wide variety of applications.

Front Panel Connectors

The 1260-136 has one 48-pin front-panel connector, labeled J200. It is a 48-pin, DIN "E" style, with 0.040" rectangular posts as pins. See **Figure 2-1** for pin numbering. **Table 2-1** shows the mapping of channel numbers to connector pins. Information about available mating connectors is provided immediately after **Table 2-1**. See **Figure 2-2** for a block diagram of the 1260-136.

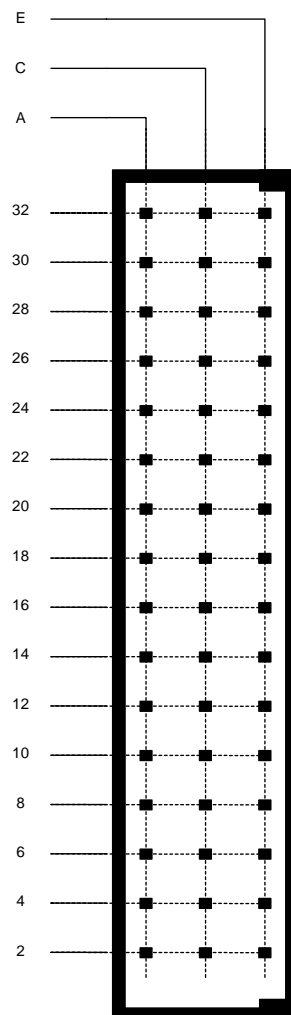

Figure 2-1, Front-Panel Connector Pin Numbering

Table 2-1, 1260-136 Front-Panel Connections

| Connector Pin Description | | | |
|---------------------------|---------|-------|------------|
| Pin # | Row A | Row C | Row E |
| 2 | 0A | 1A | 2A |
| 4 | 0B | 1B | 2B |
| 6 | 3A | 4A | 5A |
| 8 | 3B | 4B | 5B |
| 10 | 6A | 7A | 8A |
| 12 | 6B | 7B | 8B |
| 14 | 9A | 10A | COMMONA |
| 16 | 9B | 10B | COMMONA |
| 18 | COMMONB | 11A | 12A |
| 20 | COMMONB | 11B | 12B |
| 22 | 13A | 14A | 15A |
| 24 | 13B | 14B | 15B |
| 26 | 16A | 17A | 18A |
| 28 | 16B | 17B | 18B |
| 30 | 19A | 20A | NO CONNECT |
| 32 | 19B | 20B | NO CONNECT |

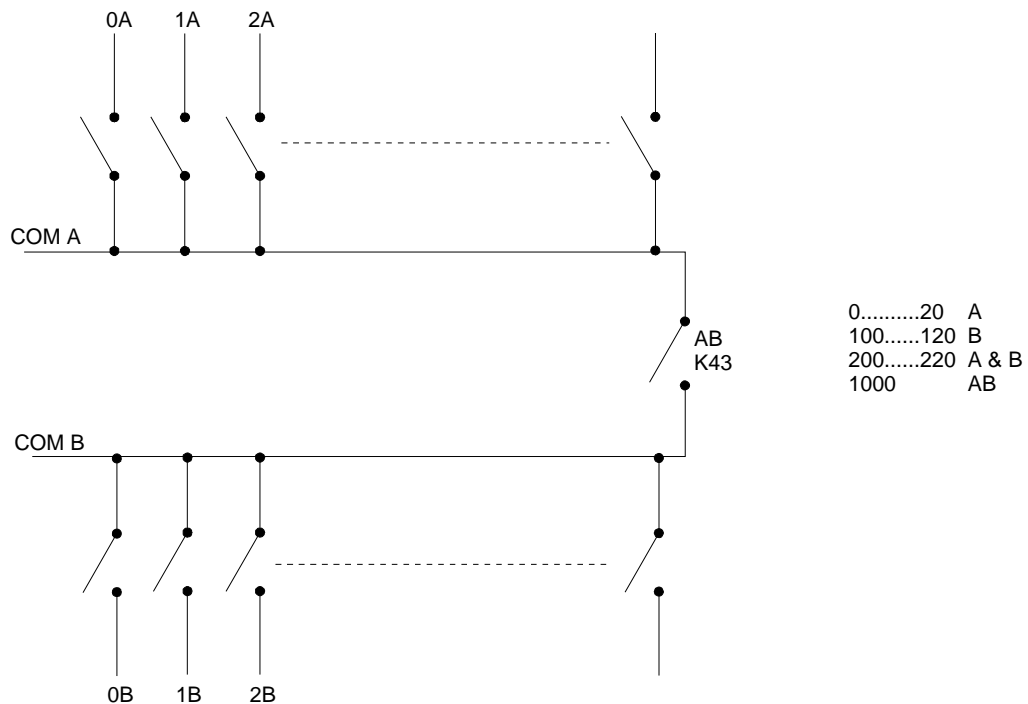

Figure 2-2, Relay Diagram

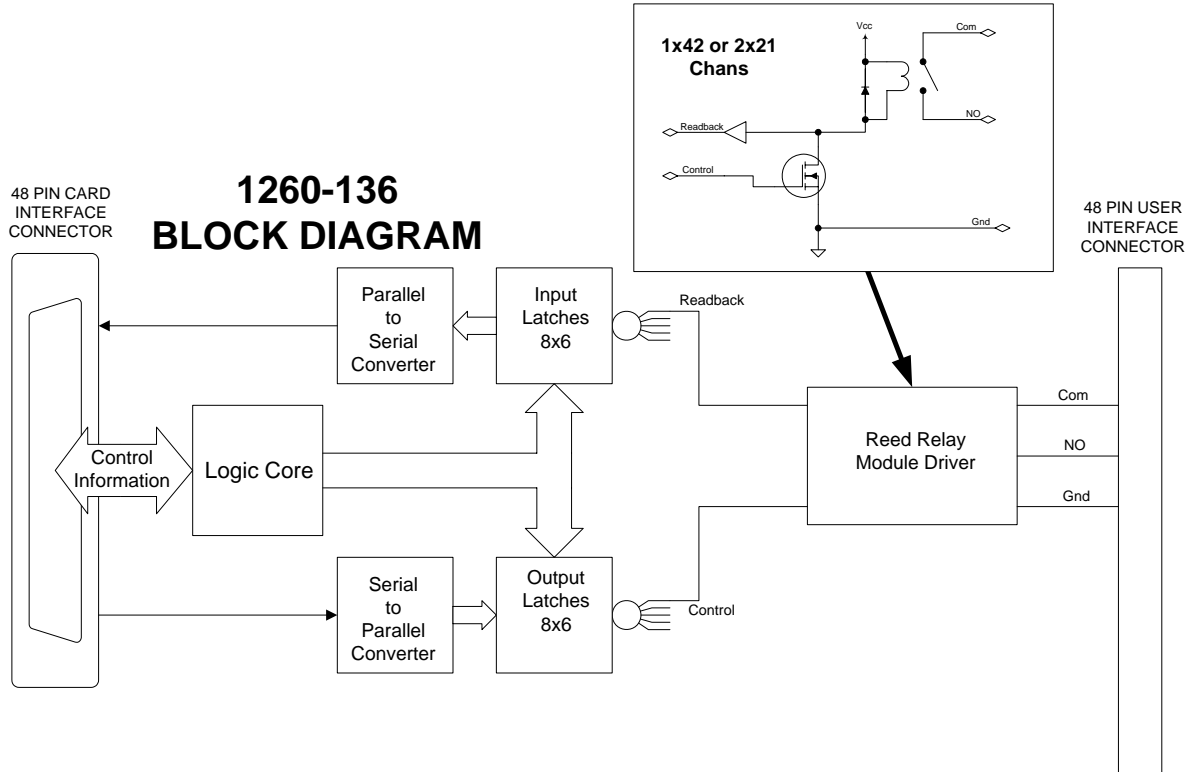

Figure 2-3, Block Diagram

Mating Connectors

Mating connector accessories are available:

160-Pin Connector Kit with backshell and pins,
P/N 407664-001

The 48-Pin Connector Kit consists of a connector housing, and 60 crimp pins. After wire attachment, the pin is inserted into the housing and will snap into place, providing positive retention.

The suggested hand tool for the crimp pins is P/N 990898. The corresponding pin removal tool is P/N 990899.

Chapter 3

MODULE OPERATION

Setting the Module Address

The Option-01T switch controller identifies each Adapt-a-Switch plug-in or conventional 1260-Series module by a *module address* that is unique to that module. The module address is a number from 1 through 12, inclusive.

The module address assigned to the 1260-136 depends on the carrier slot into which the 1260-136 is inserted, and on the position of the logical address DIP switch on the carrier side panel. The switch has two settings:

- 1-6 (closed): When the switch is set to this position, the module addresses of the plug-ins in the 1260-100 Carrier are from 1 through 6. The module with address 1 is in the left slot of the top row. The plug-ins are addressed in the following pattern:

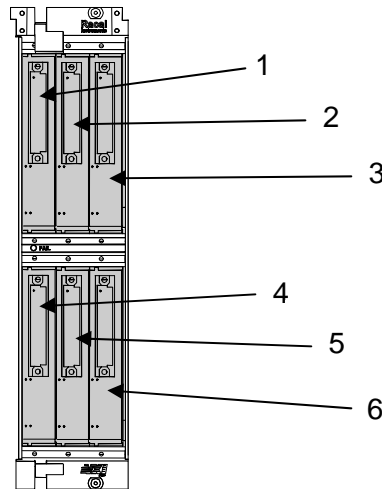

Front View – Module Addresses for 1 through 6

- 7 - 12 (open): When the switch is set to this position, the module addresses of the plug-ins in the 1260-100 Carrier are from 7 through 12, in the following pattern:

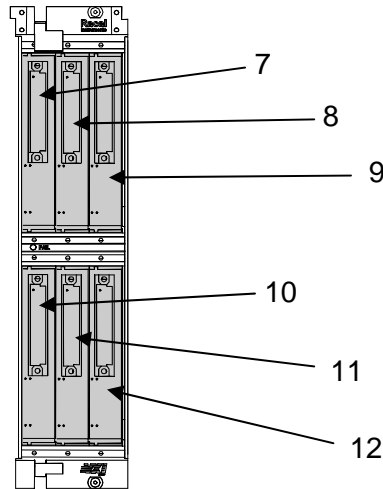

Front View – Module Addresses for 7 through 12

When setting module addresses for Adapt-a-Switch Carriers and conventional 1260-Series modules, be sure that no address is used by more than one plug-in or 1260-Series module.

For instructions on setting module addresses for a conventional 1260-Series module, see the label on the side panel of the module.

Operating Modes

The 1260-136 may be operated either in *message-based* mode or in *register-based* mode.

In the *message-based* mode, the 1260-01T switch controller interprets commands sent by the slot 0 controller, and determines the appropriate data to send to the control registers of the 1260-136 module.

If the A24 VXI base address for the 1260-100 Adapt-A-Switch carrier is assumed to be at 0x804000A for example purposes and the 1260-136 occupies the module 0 slot, **Figure 3-1** below provides a conceptual view of the message-based mode of operation for a read operation on port 1.

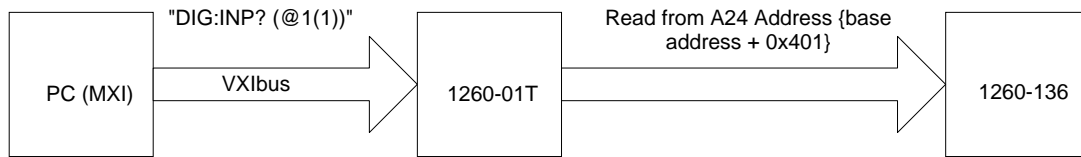

Figure 3-1, Message-Based Mode of Operation

In the *register-based* mode, the user writes directly to the port registers on the 1260-136 module. The 1260-01T command module does not monitor these operations, and does not keep track of the port states on the 1260-136 module in this mode.

A conceptual view of the register-based mode is shown in **Figure 3-2** below.

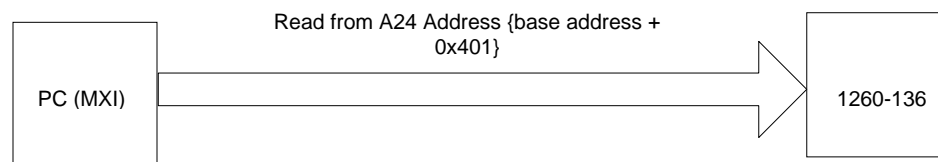

Figure 3-2, Register-Based Mode of Operation

Since the 1260-01T switch controller does not keep track of port and control register states during the register-based mode, it is advisable to use **either** the message-based or the register-based mode consistently, and use the chosen mode exclusively throughout the application program.

In general, the message-based mode of operation is easier to use with utility software such as the National Instruments VXI Interactive Control (VIC) program. The message-based mode allows the user to send ASCII text commands to the 1260-01T and to read replies from the 1260-01T. In addition, some features, such as synchronous port operation, are available only in the message-based mode. An added benefit of message-based operation is that it obviates the need to manually configure control registers on the 1260-136, controlling such things as port data direction, since these are handled automatically by the 1260-01T.

The register-based mode provides faster and more direct control of the 1260-136. In this mode, direct port and control register operations are processed in less than 9 microseconds, not counting software overhead inherent in I/O libraries such as VISA.

For further information about message-based vs. register-based comparisons, consult the 1260-01T User's Manual for further details.

Operating In Message-Based Mode

Port Descriptors For The 1260-136

The standard 1260-01T commands are used to operate the 1260-136 module. These commands are described in the 1260-01T User's Manual.

Each 1260-01T port command uses a *port descriptor* (also referred to as a *channel descriptor* in some documentation) to select the port(s) of interest. The syntax for a port descriptor is the same for all 1260 series modules. In general, the following syntax is used to select a single port:

```
(@ <module address> ( <port> ) )
```

Where:

- <module address> is the address of the 1260-136 module. This is a number in the range from 1 through 12, inclusive.
- <port> is the 1260-136 port to operate. This is a number in the range from 0 through 1000.

| | | | |
|---------|---------|--|------|
| "Ports" | 0-20 | A Relays | 0 0A |
| | | | 1 1A |
| | | | 2 2A |
| | | | etc. |
| | 100-120 | B Relays | 0 0B |
| | | | 1 1B |
| | | | etc. |
| | 1000 | AB Relay (determines whether the card is configured as 2X21 or 1X42) | |

Multiple individual ports may be specified using the following port descriptor syntax:

```
@ <module address> ( <port1> , <port2>  
, . . . , <portN> ) [,data]
```

A range of ports may be specified using the following channel descriptor syntax:

```
@ <module address> ( <first port> :  
<last port> )
```

The following examples illustrate the use of the port descriptors for the 1260-136:

```
CLOSE (@8(0))           Closes port 0 relay at module  
                        address 8
```

```
OPEN (@3(1))            Reads port 1 relay at module  
                        address 3
```

Reply To The MOD:LIST? Command

The 1260-01T returns a reply to the MOD:LIST? command. This reply is unique for each different 1260 series switch module. The syntax for the reply is:

```
<module address> : <module-specific identification string>
```

The <module-specific identification string> for the 1260-136 depends on the version. For the TTL, CMOS, standard open-collector and high voltage/current open collector, the strings are respectively:

```
1260-136B 500V 1X42 (2X21) MUX
```

```
1260-136C 1 KV 1X42 (2X21) MUX
```

```
1260-136D MERCURY 1X42 (2X21) MUX
```

So, for a 1260-136C whose <module address> is set to 8, the reply to this query would be:

```
8 : 1260-136C 1 KV 1X42 (2X21) MUX
```

Operating The 1260-136 in Register-Based Mode

In register-based mode, the 1260-136 is operated by directly writing and reading to/from ports controlling eight relays each. To access the various registers the following details must be assembled to generate an absolute address that can be wrote or read from:

The port and control registers are located in the VXIbus A24 Address Space. The A24 address for a port or control register depends on:

1. The A24 Address Offset assigned to the 1260-01T module by the Resource Manager program. The Resource Manager program is provided by the VXIbus slot-0 controller vendor. The A24 Address Offset is placed into the "Offset Register" of the 1260-01T by the Resource Manager.
2. The <module address> of the 1260-136 module. This is a value in the range from 1 and 12 inclusive.
3. The 1260-136 port or control register to be written to or read from. Each register on the 1260-136 has a unique offset from the base address.

The base A24 address for the 1260-136 module may be calculated by:

$$(A24 \text{ Offset of the } 1260-01T) + (1024 \times \text{Module Address of } 1260-136).$$

The A24 address offset is usually expressed in hexadecimal. A typical value of 204000_{16} is used in the examples that follow.

A 1260-136 with a module address of 7 would have the base A24 address computed as follows:

$$\begin{aligned} \text{Base A24 Address of } 1260-136 &= 204000_{16} + (400_{16} \times 7_{10}) \\ &= 205C00_{16} \end{aligned}$$

The port and control registers for Adapt-a-Switch plug-ins and conventional 1260-Series modules are always on odd-numbered A24 addresses. For port registers, the 1260-136 reads and writes to the same location. For control registers, the 1260-136 writes to one location, but reads back from another. **Table 3.1- 3.9** provides offsets relative to the base address of the module for all port and control registers of the 1260-136. To obtain the absolute address where data is to be written or read from, the base address is added to the offset:

$$(\text{Base A24 } 1260-136 \text{ Address}) + \text{offset} = \text{absolute address}$$

So, for our example base A24 address computed earlier, the following absolute addresses would apply for the operations indicated:

- 205C01 Port A read or written at this location
- 205E01 ID register read at this location

Before explaining the particulars of reading and writing to port and control registers, it is necessary to understand how the registers interact with the 1260-136 relays. **Table 3.2 through 3.9** provide a detailed explanation of each register and how it interacts with the 1260-136 module.

Table 3-1, Register Offset Addresses of the 1260-136 Module

| Register Name | Register Offsets to Add to Base Module Address | |
|------------------|--|-----------------------------|
| | Write Location (hexadecimal) | Read Location (hexadecimal) |
| Port A | 0x01 | 0x01 |
| Port B | 0x03 | 0x03 |
| Port C | 0x05 | 0x05 |
| Port D | 0x07 | 0x07 |
| Port E | 0x09 | 0x09 |
| Port F | 0x0B | 0x0B |
| ID | Read Only | 0x201 |
| EPROM Descriptor | Read Only | 0x203 |

Table 3-2, ID Register Functionality of the 1260-136

| Register Table | | ID Register |
|----------------|-----|----------------------------------|
| Module Version | Bit | Functionality Description |
| All | 0 | Always Reads 0x00 (Read Only) |
| | 1 | |
| | 2 | |
| | 3 | |
| | 4 | |
| | 5 | |
| | 6 | |
| | 7 | |

Table 3-3, Port A Register Functionality of the 1260-136 Module

| Register Table | | Port A | |
|----------------|-----|---------------------------|-------------------------------------|
| Module Version | Bit | Functionality Description | |
| All | 0 | Relay 0A | (0: contact open 1: contact closed) |
| | 1 | Relay 0B | (0: contact open 1: contact closed) |
| | 2 | Relay 1A | (0: contact open 1: contact closed) |
| | 3 | Relay 1B | (0: contact open 1: contact closed) |
| | 4 | Relay 2A | (0: contact open 1: contact closed) |
| | 5 | Relay 2B | (0: contact open 1: contact closed) |
| | 6 | Relay 3A | (0: contact open 1: contact closed) |
| | 7 | Relay 3B | (0: contact open 1: contact closed) |

Table 3-4, Port B Register Functionality of the 1260-136 Module

| Register Table | | Port B | |
|----------------|-----|---------------------------|-------------------------------------|
| Module Version | Bit | Functionality Description | |
| All | 0 | Relay 4A | (0: contact open 1: contact closed) |
| | 1 | Relay 4B | (0: contact open 1: contact closed) |
| | 2 | Relay 5A | (0: contact open 1: contact closed) |
| | 3 | Relay 5B | (0: contact open 1: contact closed) |
| | 4 | Relay 6A | (0: contact open 1: contact closed) |
| | 5 | Relay 6B | (0: contact open 1: contact closed) |
| | 6 | Relay 7A | (0: contact open 1: contact closed) |
| | 7 | Relay 7B | (0: contact open 1: contact closed) |

Table 3-5, Port C Register Functionality of the 1260-136 Module

| Register Table | | Port C | |
|----------------|-----|---------------------------|-------------------------------------|
| Module Version | Bit | Functionality Description | |
| All | 0 | Relay 8A | (0: contact open 1: contact closed) |
| | 1 | Relay 8B | (0: contact open 1: contact closed) |
| | 2 | Relay 9A | (0: contact open 1: contact closed) |
| | 3 | Relay 9B | (0: contact open 1: contact closed) |
| | 4 | Relay 10A | (0: contact open 1: contact closed) |
| | 5 | Relay 10B | (0: contact open 1: contact closed) |
| | 6 | Relay 11A | (0: contact open 1: contact closed) |
| | 7 | Relay 11B | (0: contact open 1: contact closed) |

Table 3-6, Port D Register Functionality of the 1260-136 Module

| Register Table | | Port D | |
|----------------|-----|---------------------------|-------------------------------------|
| Module Version | Bit | Functionality Description | |
| All | 0 | Relay 12A | (0: contact open 1: contact closed) |
| | 1 | Relay 12B | (0: contact open 1: contact closed) |
| | 2 | Relay 13A | (0: contact open 1: contact closed) |
| | 3 | Relay 13B | (0: contact open 1: contact closed) |
| | 4 | Relay 14A | (0: contact open 1: contact closed) |
| | 5 | Relay 14B | (0: contact open 1: contact closed) |
| | 6 | Relay 15A | (0: contact open 1: contact closed) |
| | 7 | Relay 15B | (0: contact open 1: contact closed) |

Table 3-7, Port E Register Functionality of the 1260-136 Module

| Register Table | | Port E | |
|----------------|-----|---------------------------|-------------------------------------|
| Module Version | Bit | Functionality Description | |
| All | 0 | Relay 16A | (0: contact open 1: contact closed) |
| | 1 | Relay 16B | (0: contact open 1: contact closed) |
| | 2 | Relay 17A | (0: contact open 1: contact closed) |
| | 3 | Relay 17B | (0: contact open 1: contact closed) |
| | 4 | Relay 18A | (0: contact open 1: contact closed) |
| | 5 | Relay 18B | (0: contact open 1: contact closed) |
| | 6 | Relay 19A | (0: contact open 1: contact closed) |
| | 7 | Relay 19B | (0: contact open 1: contact closed) |

Table 3-8, Port F Register Functionality of the 1260-136 Module

| Register Table | | Port F | |
|----------------|-----|---------------------------|-------------------------------------|
| Module Version | Bit | Functionality Description | |
| All | 0 | Relay 20A | (0: contact open 1: contact closed) |
| | 1 | Relay 20B | (0: contact open 1: contact closed) |
| | 2 | Relay 21A | (0: contact open 1: contact closed) |
| | 3 | Relay 21B | (0: contact open 1: contact closed) |
| | 4 | Reserved | |
| | 5 | Reserved | |
| | 6 | Reserved | |
| | 7 | Relay AB | (0: 2X21 mode 1: 1X42 mode) |

Table 3-9, EPROM Descriptor Functionality of the 1260-136 Module

| Register Table | | EPROM Descriptor Register |
|----------------|-----|---|
| Module Version | Bit | Functionality Description |
| All | 0 | This register each time read advances a memory pointer to the next memory location in an EPROM. To reset this pointer to the beginning, simply read the ID register and the memory pointer resets to zero. The descriptor register contains a long string of data, typically used by the Adapt-a-Switch carrier for configuration purposes. Additionally, this data has the card identification string for the specific type of card (i.e. 1260-136 500V or 1260-136 1KV). These identification strings are located at EPROM memory locations 0x23-0x34 |
| | 1 | |
| | 2 | |
| | 3 | |
| | 4 | |
| | 5 | |
| | 6 | |
| | 7 | |

Writing to a port location is a straightforward process. Setting a bit high in a port register causes the port to output a high logic level on the port pin corresponding to that bit. In the case of an open-collector version, this same operation would cause the pull-down transistor to activate.

It is especially important to realize that a single write operation controls eight separate control lines or output devices simultaneously. Therefore if only a single bit change is desired, the following process must be observed.

1. Read the register first, inverting the bit pattern if necessary
2. Mask the appropriate bit with an 'AND' operation and a byte mask with all undesired bits set to a '1' and the desired bit set to a '0' or '1' depending on whether the bit is to be set or cleared in the desired register
3. Write the masked data back into the register

As simple as this may seem, a number of products reported as faulty and sent back for repair are nothing more than the result of inappropriate register accesses.

Reading certain 1260-136 registers highlights a detail that must also be considered. Because of the 1260-136 relay driver architecture, registers A-F will readback inverted from what was written to the register.

The VISA I/O library may be used to control the module. The VISA function `viOut8()` is used to write a single 8-bit byte to a control register, while `viIn8()` is used to read a single 8-bit byte from the control register. The following code example shows the use of `viOut8()` to update the 1260-136 module.

1260-136 Example Code

```
#include <visa.h>

/* This example shows a 1260-01T at logical address 16 and a VXI/MXI */
/* interface */
#define RI1260_01_DESC      "VXI::16"

/* For a GPIB-VXI interface, and a logical address of 77 */
/* the descriptor would be: "GPIB-VXI::77" */

/* this example shows a 1260-136 with module address 7, port 1,
and write data of 0xAA */
#define MOD_ADDR_136      7
#define PORT_NUMBER      1
#define DATA_ITEM        0xAA

void example_operate_1260_136(void)
{
    ViUInt8 creg_val;
    ViBusAddress portA_addr, offset;
    ViSession hdl1260;      /* VISA handle to the 1260-01T */
    ViSession hdlRM;       /* VISA handle to the resource manager */
    ViStatus error;       /* VISA error code */

    /* open the resource manager */
    /* this must be done once in application program */
    error = viOpenDefaultRM (&hdlRM);

    if (error < 0) {
        /* error handling code goes here */
    }

    /* get a handle for the 1260-01T */
    error = viOpen (hdlRM, RI1260_01_DESC, VI_NULL,VI_NULL, &hdl1260);
    if (error < 0) {
        /* error handling code goes here */
    }

    /* form the offset for control register 0 */
    /* note that the base A24 Address for the 1260-01T */

```

```
/* is already accounted for by VISA calls viIn8() and */
/* viOut8() */

/* module address shifted 10 places = module address x 1024 */
portA_addr = (MOD_ADDR_136 << 10) + 1;
offset = portA_addr + (PORT_NUMBER << 1);

error = viOut8 (vi, VI_A24_SPACE, offset, DATA_ITEM);

if (error < 0)

    return( error );

/* close the VISA session */
error = viClose( hdl1260 );
if (error < 0) {
    /* error handling code goes here */
}
}
```

Chapter 4
OPTIONAL ASSEMBLIES

| | | |
|------------|--|-----|
| 407664 | Connector Kit, 160 Pin Crimp | 4-3 |
| 407408-001 | Cable Assy, 160 Pin, 6 ft, 24AWG | 4-4 |

This page was left intentionally blank.

Assembly 407664

Connector kit, 160 Pin, Crimp Rev Date 7/30/98 Revision A

| # | Component | Description | U/M | Qty Reqd. | REF |
|----------|------------------|----------------------|------------|------------------|------------|
| 1 | 602258-116 | CON-CAB-RCP160C,100S | -E EA | 1.000 | |
| 2 | 602258-900 | TRMCRP-SNP-U-F26-20G | -E EA | 170.000 | |

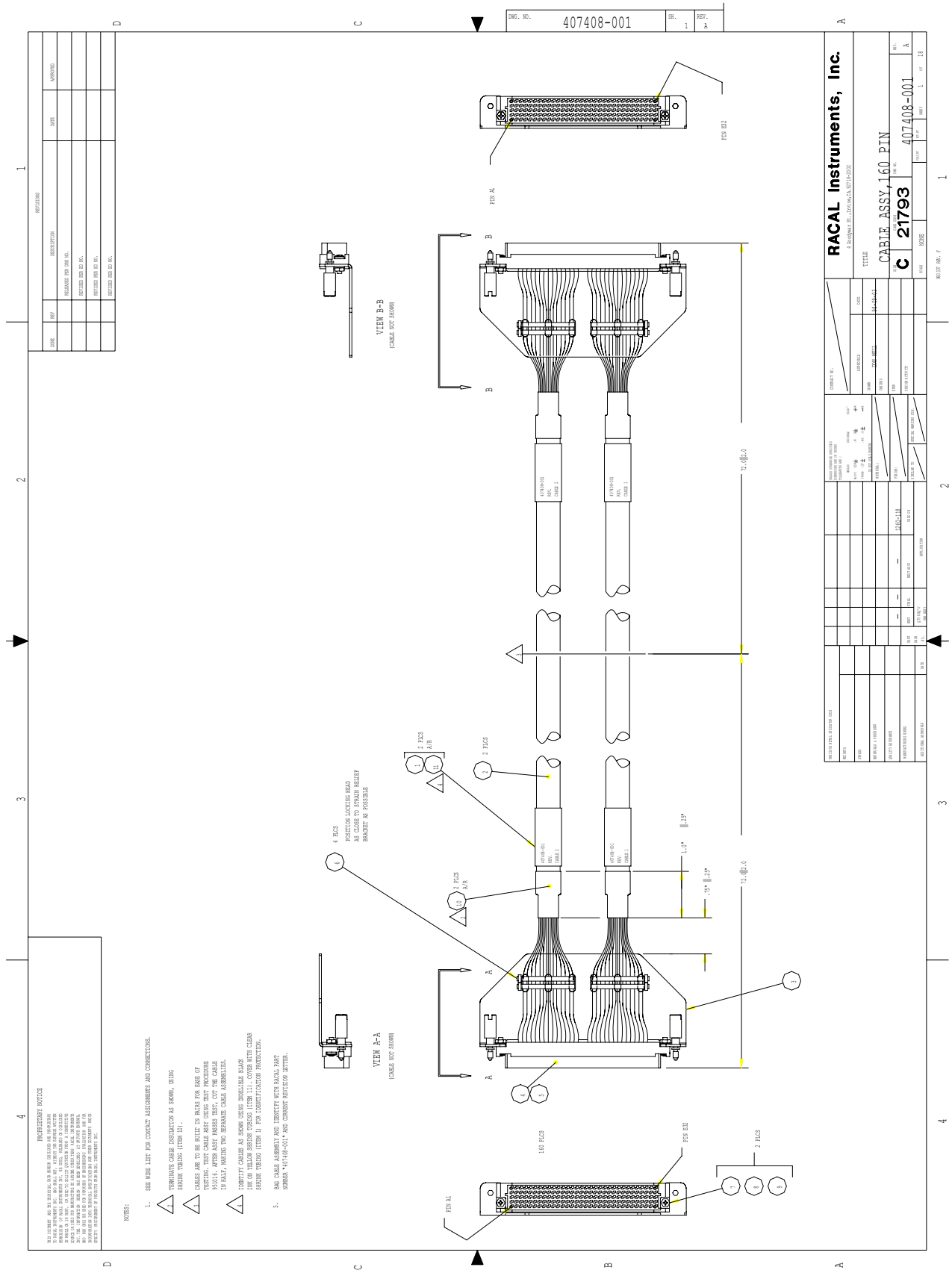

PRODUCT SUPPORT

Product Support

EADS North America Defense Test and Services, Inc. has a complete Service and Parts Department. If you need technical assistance or should it be necessary to return your product for repair or calibration, call 1-800-722-3262. If parts are required to repair the product at your facility, call 1-949-859-8999 and ask for the Parts Department.

When sending your instrument in for repair, complete the form in the back of this manual.

For worldwide support and the office closest to your facility, refer to the website for the most complete information <http://www.eads-nadefense.com>.

Warranty

Use the original packing material when returning the 1260-136 to EADS North America Defense Test and Services, Inc. for calibration or servicing. The original shipping container and associated packaging material will provide the necessary protection for safe reshipment.

If the original packing material is unavailable, contact EADS North America Defense Test and Services, Inc. Customer Service at 1-800-722-3262 for information.

REPAIR AND CALIBRATION REQUEST FORM

To allow us to better understand your repair requests, we suggest you use the following outline when calling and include a copy with your instrument to be sent to the EADS North America Defense Test and Service, Inc. Repair Facility.

Model _____ Serial No. _____ Date _____

Company Name _____ Purchase Order # _____

Billing Address _____

City

State/Province

Zip/Postal Code

Country

Shipping Address _____

City

State/Province

Zip/Postal Code

Country

Technical Contact _____ Phone Number () _____

Purchasing Contact _____ Phone Number () _____

1. Describe, in detail, the problem and symptoms you are having. Please include all set up details, such as input/output levels, frequencies, waveform details, etc.

2. If problem is occurring when unit is in remote, please list the program strings used and the controller type.

3. Please give any additional information you feel would be beneficial in facilitating a faster repair time (i.e., modifications, etc.)

4. Is calibration data required? Yes No (please circle one)

Call before shipping Ship instruments to nearest support office.
 Note: We do not accept
 "collect" shipments.